

Operator's Manual SUPPLEMENT

MANCO MODEL NO.

415-08

WARNING:
Read Engine
Owner's Manual,
Vehicle Operator's
Manual, and
Supplement
Carefully Before
Operating
Vehicle.

Parts List

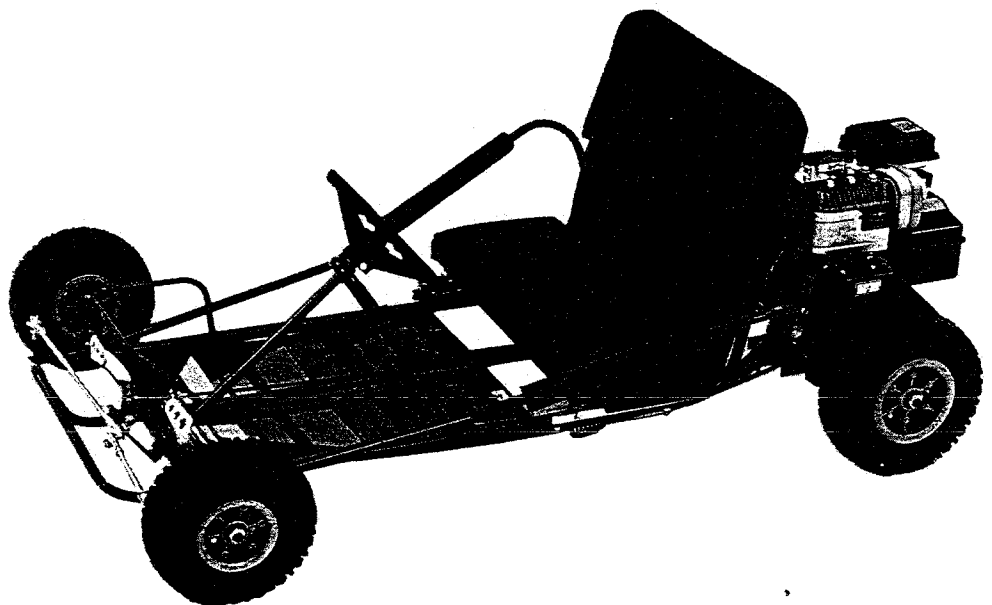

MANCO
PRODUCTS, INC.

4404 Engle Ridge Drive Ft. Wayne, Indiana 46804 219-432-1596

**THIS VEHICLE IS FOR
OFF-ROAD USE ONLY**

BEFORE OPERATING THIS VEHICLE, THE OWNER AND/OR OPERATOR MUST UNDERSTAND THE VEHICLE WAS NOT DESIGNED OR MANUFACTURED TO MEET SPECIFICATIONS FOR USE ON PUBLIC ROADS, STREETS, HIGHWAYS, OR THOROUGHFARES AND HAVE READ AND HAVE AN UNDERSTANDING OF ALL THE INSTRUCTIONS FOR SAFE ASSEMBLY AND OPERATION AS WELL AS THE INSTRUCTIONS GOVERNING THE ENGINE AND OTHER PORTIONS OF THE VEHICLE.

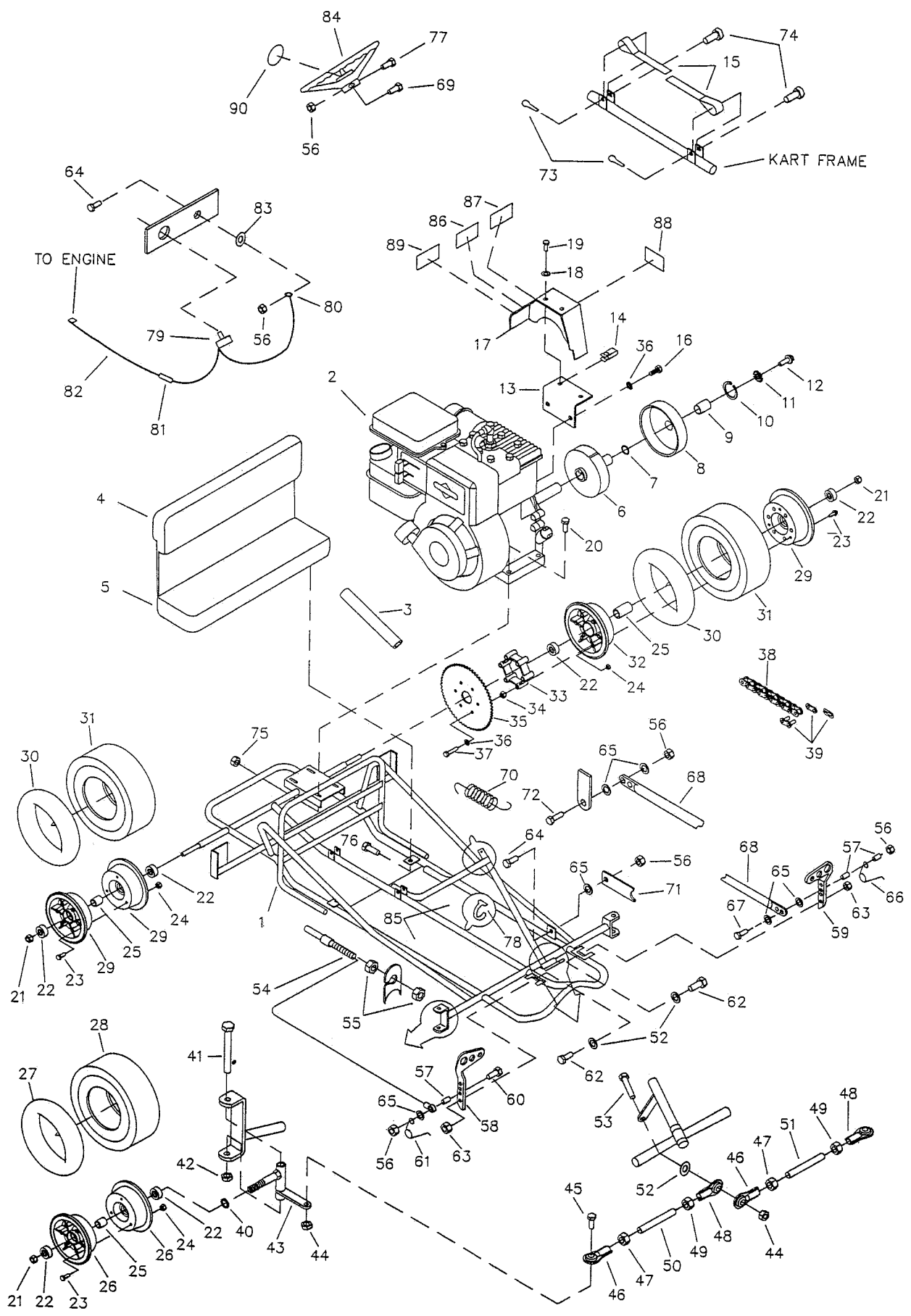

REPAIR PARTS - MODEL 415-08

REF NO.	PART NO.	DESCRIPTION	REF NO.	PART NO.	DESCRIPTION
1	3318-19	Frame	53	9145	Bolt, 3/8-16 x 1.75"
2	1763	Engine, 5hp	54	1390	Throttle Cable w/ Housing (inc. REF 55)
3	5945	Arm Pads w/ Covers (QTY 2)	55	9058	Nut, 5/16-24 Jam
4	4328	Seat Back	56	9057	Nut, 1/4-20 Toplock
5	4327	Seat Bottom	57	1389	Bushing
ASM	4335	Clutch Assembly (inc. REF 6-10)	58	1437	Pedal, Throttle
6	4496	Clutch Rotor	59	1436	Pedal, Brake
7	3146	Washer, Fiber	60	1847	Bolt, 1/4-20 x 1.00"
8	4491	Drum w/ Sprocket (inc. REF 9)	61	5902	Spring, Left Wound
9	3143	Bushing	62	9110	Bolt, 5/16-18 x 1.75"
10	3141	Snap Ring	63	1189	Nut, 5/16-18 Toplock
11	9001	Washer, 3/8 Int/Ext Lock	64	1845	Bolt, 1/4-20 x .625"
12	1491	Bolt, 5/16-24 x .75"	65	1854	Washer, #14 Flat
13	3363-2	Bracket, Chainguard	66	5903	Spring, Right Wound
14	5135	Clip Nut	67	1849	Bolt, 1/4-20 x 1.50"
15	4372	Handhold Strap	68	5097	Brake Rod
16	9101	Bolt, 5/16-24 x .50"	69	9160	Bolt, 1/4-20 x .875"
17	3362	Chainguard	70	4365	Spring
18	6039	Washer, #10 Lock	71	1982	Pedal Latch
19	6046	Screw, #10-24 x .50"	72	1846	Bolt, 1/4-20 x .75"
20	9186	Bolt, 5/16-18 x 1.50"	73	9116	Cotter Pin
21	1046	Nut, 5/8-11 Toplock	74	9118	Clevis Pin
ASM	2497	Front Wheel Assembly (inc. REF 22-28)	75	1263	Nut, 5/16-18 Flange
ASM	2247	Idle Wheel Asm (inc. REF 22-25,29-31)	76	1876	Bolt, 1/4-20 x .625"
ASM	4337	Drive Wheel Asm (inc. REF 22-25,29-37)	77	9080	Bolt, 1/4-20 x 2.75"
22	1093	Bearing	78	1019	Ty-Wrap
23	5839	Bolt, 1/4-20 x .75"	ASM	4419	Stop Switch Assembly (inc. REF 79-82)
24	1186	Nut, 1/4-20	79	1392	Stop Switch
25	5949	Spanner	80	1393	Ring Terminal
26	5158	Wheel Half, Front 4"	81	2650	Butt Connector
27	1053	Tube, Front 4"	82	5642	Wire w/ Terminal
28	2244	Tire, Front 4.10/3.50 x 4" Knobby	83	5732	Washer, 1/4 Int/Ext Lock
29	8004	Wheel Half, Rear 5" Untapped	84	6038	Steering Wheel
30	1753	Tube, Rear 5"	85	5944	Decal, Floor Pan (L & R)
31	2246	Tire, Rear 4.10/3.50 x 5" Knobby	86	1049	Decal, Caution
32	8006	Wheel Half, Rear 5" Tapped	87	4912	Decal, Warning
33	8008	Spacer	88	6791	Decal, Oil Clutch
34	2388	Nut, 3/8-24	89	6612	Decal, Tire Pressure
35	8007	Sprocket, #35 Chain x 60 Teeth	90	5946	Decal, Steering Wheel Center
36	9030	Washer, 5/16 Lock	NI	4350	Vehicle Operator's Manual
37	9127	Bolt, 5/16-18 x 2.25"	NI	2601	Engine Owner's Manual
38	8050	Chain, #35 x 68 Pitch (inc. REF 39)			
39	1269	Master Link, #35 Chain			
40	1937	Spacer, 5/8 ID x .25" Thick			
41	1264	Bolt, 1/2-13 x 3.50"			
42	1012	Nut, 1/2-13 Toplock			
43	8021	Spindle, Right Side			
NI	8020	Spindle, Left Side			
44	9085	Nut, 3/8-16 Toplock			
45	9146	Bolt, 3/8-16 x 1.50"			
ASM	4359	Tie Rod Assembly (inc. REF 46-50)			
ASM	4358	Tie Rod Assembly (inc. REF 46-49,51)			
46	1414	Tie Rod End, Right Hand Thread			
47	9092	Nut, 3/8-24 Jam, Right Hand Thread			
48	1415	Tie Rod End, Left Hand Thread			
49	9024	Nut, 3/8-24 Jam, Left Hand Thread			
50	5003	Tie Rod, Long			
51	4356	Tie Rod, Short			
52	9091	Washer, 3/8 Flat			

ASM = Assembly
NI = Not Illustrated

THROTTLE CABLE INSTALLATION

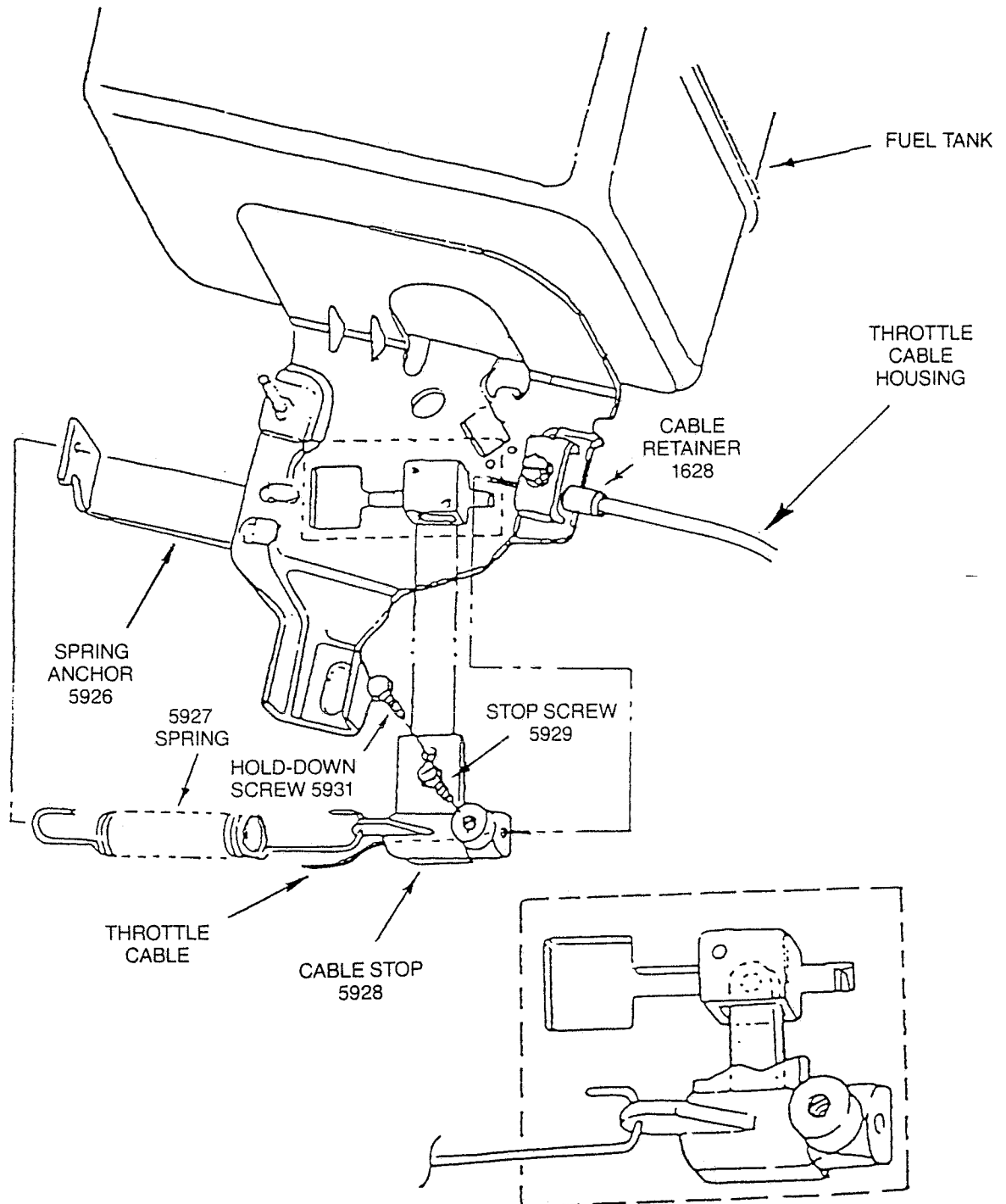

ASSEMBLY: Pass the throttle cable through the cable retainer and butt the throttle cable housing end against the inside shoulder of the cable retainer. (The cable retainer is to be securely fastened to the engine with the clamping screw.) Pass the end of the Throttle Cable through the hole in the cable stop. Before tightening cable stop screw:

1. Ensure spring anchor, spring, and cable are installed as illustrated above.
2. Ensure throttle pedal is in rearward (idle) position.
3. Ensure that there is no slack in the throttle cable with *no* tension applied to return spring.
4. Ensure cable housing is inside and against the cable retainer.