

# CHAIN SAW

UT10184,R  
UT10400,R  
UT10439,R  
UT10452,2,4  
UT10531  
UT10547  
UT10554  
UT10555



## PARTS LIST

PRICE .35  
PART NO. 24535  
REVISION 1  
PRINTED IN U.S.A.

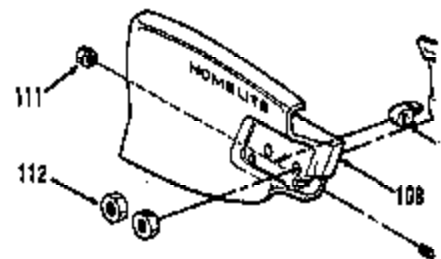
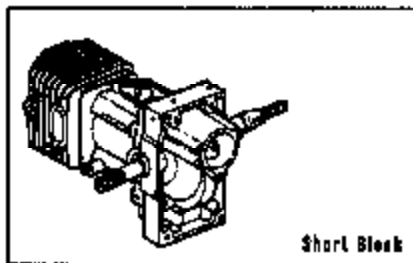
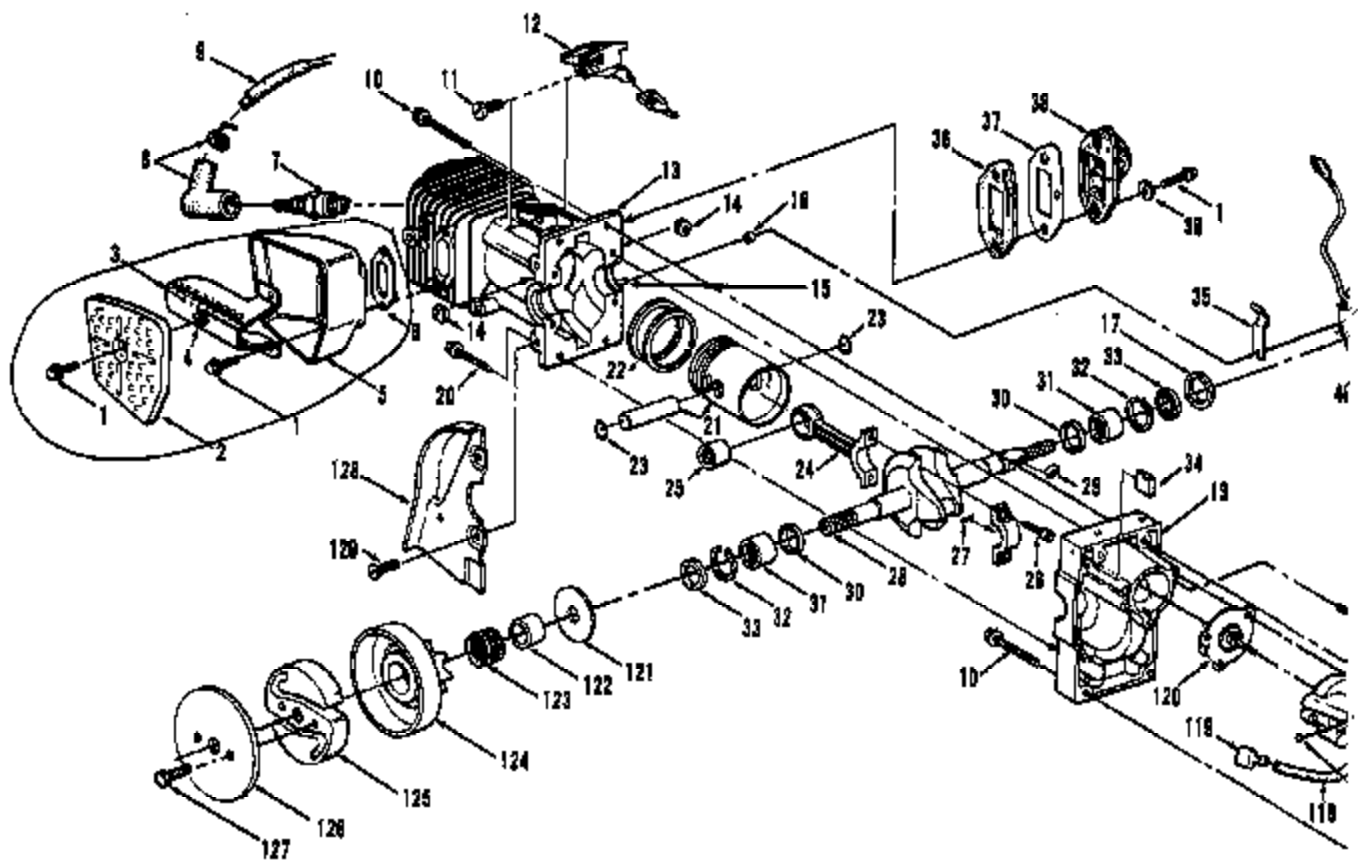
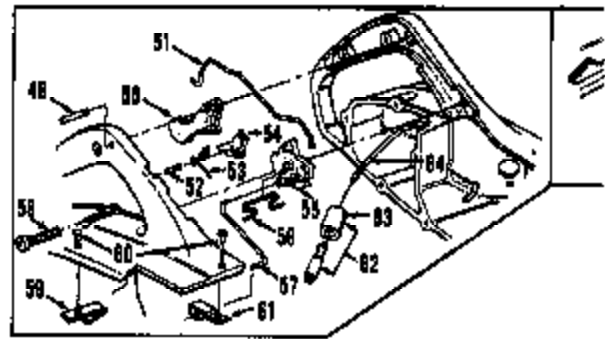
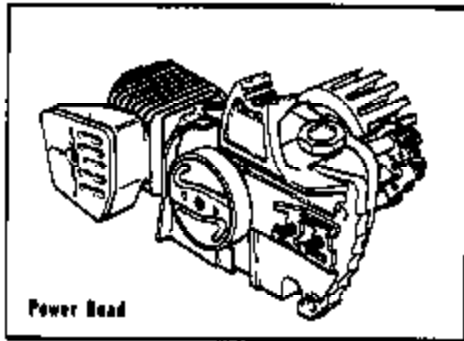



No.	Description	Part No.	Qty.	No.	Description	Part No.	Qty.
1	SCREW-hex washer hd., 8-32 x 1/2	80983	7	66	DEFLECTOR-air	88594	1
2	CAP-muffler (diffuser type)	88805-I	1	68	BUSHING-flanged	88860	2
	CAP-muffler - accessory - (lower type)	88847-I	1	67	SCREW-hex washer hd., 10-32 x 2	82224	2
	W/C ARRESTOR-spark (accessory-not shown)	A-88866-I	1	68	CAP-fuel filler	A-88800	1
3	BAFFLER-muffler	A-88864	1		Includes:		
	Includes:			69	FILTER-filler cap	49464	1
4	NUT-ohlock, 8 x 32	81224	1	70	VALVE-ohlock	69461	1
6	BODY-muffler	88846-I	1	71	GASKET-fuel filler cap (note 4)	69501	1
7	GASKET-muffler	88842	1	72	CHAIN-head	88802	1
8	SPARK PLUG	88816-B	1	73	SCREW-pan hd., 6 x 1/4 Plastic	82286	1
9	TERMINAL-high tension lead	A-88873-A	1	74	RETAINER-filler cap (note 4)	89503	1
9	SLEEVE-wire (fiberglass)	88828	1	75	BUTTON-ohlock	88861	1
10	SCREW-hex washer hd., 8-32 x 1-1/4	82194	4	*76	SCREW-Sems hex hd., slotted, 10-24 x 5/8	89335-A	4
11	SCREW-pan hd., Plastic, 8 x 3/8	82216	2	77	ELEMENT-air filter	88832	1
12	TERMINAL & INSULATION	A-89341	1	78	COVER-air filter	88831-A	1
	SOCKET BLOCK	A-88824-C	1	79	SCREW-filter cover retaining	88835	1
	Includes:			80	SCREW-hex washer hd.	80983	3
13	CYLINDER & CRANKCASE (note 1)	A-88843-C	1		STARTER-complete	A-88811-A	1
	Includes:				Includes:		
14	NUT-hex centerlock, 8-32	81223	4	81	HOUSING-starter	A-88823-A	1
15	PIN-dowel	84302	1	*82	INSERT-starting rope	88837-A	1
16	SEAL-post	89448	1	*83	ORIP-starting rope	64165-B	1
*17	SEAL	89973	1	84	SPRING-rewind	65107	1
18	SCREW-Sems hex hd., 8-32 x 1	89021	4	85	RETAINER-rewind spring	88812	1
19	POINTS-breaker (note 2)	A-89483	1	86	PULLEY-starter	A-88845	1
20	SCREW-hex washer hd., 8-32 x 3/4	82248	2	87	ROPE-starter, 1/4 (42" in length)	88328	1
21	PETON & PIN	A-88842	1	88	SPACER-carburetor	88837	1
	Includes:			89	CARBURETOR-Walbro HDC 20	A-88957	1
22	RING-piston	88808	2	90	SPRING-choise	88864-A	1
22	RING-retaining	84813	2	91	ROD-choke	88862	1
24	ROD-connecting	A-88818	1	92	HANDLE BAR	A-88888-1	1
	Includes:			93	SCREW-hex washer hd.	82218	3
25	BEARING-needle	88818	1	94	COIL-ignition	A-88849	1
*26	SCREW-cap hex socket hd.	89919	2		Includes:		
27	BEARING-needle (set 18)	A-88511	1	95	LEAD-hi tension	88828	1
28	CRANKSHAFT	88507-1	1		RETAINER-coil (not shown)	88267	1
29	KEY-woodruff	85128	1	96	SCREW-hex washer hd.	82248	3
30	BEARING-thrust	88509	2	97	CORE-coil	A-88848	1
31	BEARING-roller	88513	2		Includes:		
32	RING-retaining	88814	2		RETAINER-coil (not shown)	88267	1
33	SEAL-shaft	88518	2	98	CONDENSER	88843	1
34	COVER-vent	88990	1	99	BLOCK-junction	88813	1
35	CLAMP-hi-tension lead	88823	1	100	CAP-oil filler	A-88807	1
36	GASKET-intake	88484	1		Includes:		
37	COVER-pulse	88872	1	101	GASKET-oil filler cap	88833	1
*38	MANIFOLD-intake	A-88830-1	1	*102	TANK-oil (note 6)	A-88802-2A	1
39	WASHER-flat, 7/16 x 3/16 x 1/16	84103	2		Includes:		
40	BOX-breaker (note 2)	A-89593	1	103	BALL-stainless steel	55217	1
	Includes:			104	BOLT-guide bar, 5/16	68753	2
	SEAL-post (index #18)	89445	1	105	NUT-hex centerlock, 10-32	81208	1
	SEAL (index #17)	89973	1	*106	PLATE-guide bar (inner)	87300-A	1
41	SCREW-pan hd., Plastic, 8 x 3/8	82216	1	*107	PLATE-guide bar (outer)	87299-A	1
42	TERMINAL-ground	88897	1	108	COVER-drivecase	A-88814-1	1
43	SCREW-pan hd., 8-32 x 2/8	80671	3		Includes:		
44	COVER-breaker box	A-88892	1	109	PIN-guide bar adjusting	88118-1	1
	Includes:			110	SCREW-guide bar adjusting	85175-A	1
45	SEAL-breaker box cover	88818-A	1	111	NUT-hex centerlock, 10-32	81208	1
46	ROTOR	88830	1	112	NUT-hex, 5/16-18	81196	2
47	NUT-rotor (left hand thread)	A-88810	1	*113	GASKET-oil tank	88880-B	1
*48	ENGINE COVER	A-88844-1	1	114	SCREW-collar spring	88819	1
	Includes:			115	SPRING-check valve	88870	1
49	PIN-trigger	88848	1	116	BALL-shock valve	80851	2
50	TRIGGER-throttle	88849	1	117	PUMP-automatic oil (note 7)	A-88863	1
51	ROD-throttle	88850	1	118	LINE-oil pick-up	88861	1
52	PIN-trigger latch	88841	1	119	FILTER-oil	A-88893	1
53	SPRING-throttle latch	88826	1	*120	PLUNGER-oil pump (note 7)	A-88883-B	1
54	LATCH-throttle	88835	1	121	WASHER-thrust	85094	1
55	BUTTON-stop switch	88880	1	122	RACE-inner	89748-A	1
56	SPRING-switch	88881	1	123	BEARING-roller	84124	1
57	LINK-grounding switch	88878	1	124	SPROCKET & DRUM	A-85093	1
58	SCREW-til. hd., 8-32 x 5/8	88148	3	*	CLUTCH & PLATE	A-89953	1
59	CLAMP-hi tension lead	88839	1		Includes:		
60	RIVET-tubular (steel)	89061	2	125	CLUTCH	88882-1A	1
61	CONTACT	88577	1	126	PLATE-clutch	89915	1
*62	FILTER-fuel	A-88823	1	127	SCREW-hex hd., 10-24 x 1/2, stainless steel	82286	2
	Includes:			128	SHIELD-sawcut	88896	1
63	ELEMENT-felt filter (note 8)	84983-1	1	129	SCREW-pan hd., Taprite, 8-32 x 5/16	82198	3
64	LINE-fuel pick-up	89862	1				

\* Denotes new parts

ALWAYS FURNISH MODEL AND SERIAL NUMBER WHEN ORDERING PARTS.

## A-69957 HDC-20

No.	Description	Part No.	Qty.
1	SCREW-fuel pump cover	67374	1
2	COVER-fuel pump	67361	1
3	GASKET-fuel pump	†67388	1
4	DIAPHRAGM-fuel pump	†67370	1
* 6	STOP-throttle (see note)	69968	1
8	SCREW-valve	†67372	3
7	SHAFT-choke	68632	1
* 8	NEEDLE-idle adjustment (see note)	69969	1
9	SPRING-needle adjustment (idle)	12189	1
10	NEEDLE-mixture adjustment	†68637	2
11	SPRING-needle adjustment	†67377	2
12	SCREEN-fuel inlet	†64243	1
*13	VALVE-throttle (see note)	69981	1
14	SPRING-throttle return	†67378	1
15	SHAFT-throttle	68636	1
16	VALVE-choke	67365	1
17	BALL-choke valve	†60081	1
18	SPRING-choke friction	†64235	1
19	SCREEN-check valve	†67381	1
20	RING-screen retaining	†67380	1
21	GASKET-circuit plate	†6798T-A	1
22	NEEDLE-inlet	†64239	1
23	SPRING-metering lever	†32249	1
24	LEVER-metering	†67383	1
25	PLATE-circuit	67382	1
26	SCREW-circuit plate	67376	2
27	GASKET-metering diaphragm	†64231	1
28	DIAPHRAGM-metering	†67371	1
29	COVER-metering diaphragm	64224	1
30	SCREW-metering cover	64483	6
*31	REPAIR KIT (see note)	69960	1
32	GASKET SET	†67069-A	1
	REPAIR KIT-check valve	68389	1

\* Denotes new parts  
 † Indicates contents of Repair Kit #69960  
 ‡ Indicates contents of Gasket Set #67383-A

**NOTE:**  
 The following parts are still required on carburetor #A-68536 (HDC-3)

STOP-throttle	68633	VALVE-throttle	67383
NEEDLE-idle adjustment	68831	REPAIR KIT	68634

**ACCESSORIES**

- ARRESTOR-spark A-68886-1
- CAP-muffler - louver type 68967-1
- \*DECAL SET A-69048-A  
 Includes: (four)  
 "CHAIN OIL", "ON-OFF", "Starting  
 Instructions", and "130 Automatic"
- GREASE-all temp multi purpose 24551
- KIT-hand guard A-69472  
 Includes:  
 LOCKWASHER-internal 68025  
 SCREW-slotted hex hd., trimmed, 10-24 x 3/8 68249  
 SPACER 69474  
 WASHER-cupped spring 69475
- KIT-splined bumper A-68666  
 Includes:  
 2 NUTS-centerlock hex., 10-32 61206  
 2 SCREWS-10-22 x 1/2 60646
- ROPE-starting, #4 size, 250 ft. reel 68848

**PAINT**

- Paint-black, 12 oz. spray can 22772
- Paint-red, 12 oz. spray can 23476

CASE-carrying A-68988

**NOTE:** SLEEVE-68817 to be used only on units prior to s/n 42411583

**TOOLS**

- GAGE-feeler (.015 pink plastic) 23466
- LOCTITE 23488-B
- PLUG-installation bearing 63756
- PULLER-magnets rotor A-24344  
 Includes:  
 4 NUTS-hex centerlock, 10-32 61206  
 4 SCREWS-hex hd. spline, 10-32 x 1-3/8 64102  
 4 WASHERS-flat, #10 64005-1
- SCREWDRIVER 24541
- SKIM-(.0125 black plastic) 24306
- SPACER-plug 24548
- WRENCH-socket 68661
- WRENCH-spanner (clutch) A-23998-A  
 Includes:  
 PIN-clutch spanner 23717-A

**NOTE 1 -** On cylinder and crankcase A-68643, A-68649-A, and A-68643-B built prior to s/n 42411543, see Branch Service Memo #91208 and Dealer Service Memo #60 for conversion to new design to eliminate use of bumper sleeve 68617 and vent passage.

**NOTE 2 -** Units prior to s/n 30871001 use breaker points A-68668 breaker box A-68647

**NOTE 3 -** Use with washer 64102 only in fuel pick-up A-63980

**NOTE 4 -** With fuel filler cap A-68283-B use gasket 68661 and retainer 68751

**NOTE 5 -** Units prior to s/n 23080586 use screw 62116

**NOTE 6 -** Units prior to s/n 13350722 use oil tank A-68609-A

**NOTE 7 -** Units with oil pump A-68683 and A-68683-A require 2 gaskets 68650-A

Part No.	Description	Qty.	Part No.	Description	Qty.	Part No.	Description	Qty.
1219P	Spring-needle	1	88818	Bearing-roller	2	A-88845	Pulley-starter	1
12249	Spring-metering lever	1	88514	Ring-retaining	2	A-88848	Core-coil	1
22488	Gags-feeler	1	A-88518	Rod-connecting	1	A-88849	Coil-ignition	1
22772	Paint-black	1	88519	Sea(-)shaft	2	88851	Wrench-socket	1
23475	Paint-red	1	*A-88520-1	Manifold-intake	1	A-88855	Kit-spiked bumper	1
23488-B	Loctite	1	A-88523-A	Housing-starter	1	A-88856-1	Arrestor-spark	1
A-23696-A	Wrench-spanner	1	88828	Rope-starter #4	1	88871	Cover-pulse	1
23786	Plug-installation	1	88530	Rotor	1	*88897-A	Insert-starting rope	1
23717-A	Pin-clutch spanner	1	88531-A	Cover-air filter	1	88848	Rope-starting	1
24906	Shim	1	88532	Element-air filter	1	A-88986	Case-carrying	1
24541	Screwdriver	1	88533	Gasket-oil filler cap	1	88986-1	Cap-muffler	1
A-24544	Puller-magneto rotor	1	88534	Deflector-air	1	88989	Cover-vent	1
24548	Spacer-plug	1	88538	Screw-filter cover	1	*A-89048-A	Decal Set	1
24551	Grease	1	88537	Spacer-carburetor	1	A-89341	Terminal & Insulation	1
88517	Ball-stainless steel	1	88542	Gasket-muffler	1	A-89363	Pump-automatic oil	1
A-88873-A	Terminal-high tension	1	88543	Condenser	1	89448	Seal-post	1
88753	Boil-5/16	2	88545-1	Body-muffler	1	89451	Valve-check	1
80081	Ball-check valve	3	88547-1	Cap-muffler	1	89454	Filter-filter cap	1
84083-1	Element-felt filter	1	88548	Pin-trigger	1	A-89472	Kit-hand guard	1
84124	Bearing-roller	1	88549	Trigger-throttle	1	89474	Spacer	1
*84188-B	Grip-starting rope	1	88550	Rod-throttle	1	89475	Washer-cupped spring	1
84224	Cover-metering	1	88551	Button-choke	1	A-89483	Points-breaker	1
84228	Needle-inlet	1	88581	Spring-switch	1	A-89500	Cap-fuel filler	1
84231	Gasket-metering	1	88584-A	Spring-choke	1	89501	Gasket-fuel filler	1
84238	Spring-choke	1	88582	Rod-choke	1	89502	Chain-bead	1
84243	Screen-fuel inlet	1	A-88557	Cap-oil filler	1	89503	Retainer-filler cap	1
84308	Pin-dowel	1	88560	Bushing-flanged	2	A-89538	Box-breaker	1
84689	Screw-metering cover	4	88561	Line-oil pick-up	1	89915	Plate-clutch	1
84813	Ring-retaining	2	88562	Line-fuel pick-up	1	A-89923	Filter-fuel	1
A-86033	Sprocket & Drum	1	A-88564	Baffle-muffler	1	*A-89933	Clutch & Plate	1
85064	Washer-thrust	1	88570	Spring-check valve	1	A-89957	Carburetor-Walbro	1
86107	Spring-rewind	1	88576	Link-grounding	1	*89958	Stop-throttle	1
88112-1	Pin-guide bar	1	88577	Contact	1	*89959	Needle-idle adjustment	1
86126	Key-woodruff	1	88580	Button-stop switch	1	*89960	Repair Kit	1
86175-A	Screw-guide bar	1	*A-88883-B	Plunger-oil pump	1	*89961	Valve-throttle	1
86386	Repair Kit	1	*88889-B	Gasket-oil tank	1	*89973	Seal	1
86744-A	Race-inner	1	88591	Terminal-ground	1	FASTENING PARTS		
*87299-A	Plate-guide bar	1	A-88592	Cover-breaker box	1	*89335-A	10-24 x 5/8	4
*87300-A	Plate-guide bar	1	A-88593	Filter-oil	1	*89919	Screw-cap socket hd.	2
87380	Ring-screen retaining	1	88598	Shield-saw dust	1	80571	8-32 x 3/8	3
87381	Cover-fuel pump	1	A-88599-1	Handle Bar	1	80848	10-22 x 1/2	2
87385	Valve-choke	1	*A-88608-2A	Tank-oil	1	80883	8-32 x 1/2	10
87387-A	Gasket-circuit plate	1	A-88610	Nut-rotor	1	81196	Nut-5/16-18	2
87388	Gasket-fuel pump	1	A-88611-A	Starter-complete	1	81208	Nut-10-32	7
87389-A	Gasket Set	1	88612	Retainer-rewind	1	81208	Nut-10-34	1
87370	Diaphragm-fuel pump	1	88613	Block-ignition	1	81223	Nut-8-32	4
87371	Diaphragm-metering	1	A-88614-1	Cover-drivecase	1	81224	Nut-9-32	1
87879	Screw-valve	3	88616-B	Spark Plug	1	82146	8-32 x 5/8	8
87374	Screw-fuel pump	1	88618-A	Seal-breaker box	1	82162	10-32 x 1-3/8	4
87375	Screw-circuit plate	2	88619	Screw-oiler spring	1	82194	8-32 x 1-1/4	4
87376	Spring-throttle	1	88623	Clamp-hi tension	1	82185	8-32 x 5/16	3
87377	Spring-needle adj.	3	A-88624-C	Short Block	1	82218	6 x 3/8	3
87381	Screen-check valve	1	88525	Sleeve-wire	1	82219	Screw-hex washer hd.	3
87382	Plate-circuit	1	88628	Spring-throttle latch	1	82224	10-32 x 2	2
87383	Lever-metering	1	88629	Lead-hi tension	1	82248	8-32 x 3/4	4
88257	Retainer-coil	1	88632	Shaft-choke	1	82249	10-24 x 5/8	1
88302-1A	Clutch	1	88636	Latch-throttle	1	82256	6 x 1/4	1
88404	Gasket-intake	1	88638	Shaft-throttle	1	82288	10-24 x 1/2	2
88507-1	Crankshaft	1	88637	Needle-mixture	2	83028	Washer-lock	1
88508	Ring-piston	2	88639	Clamp-hi tension lead	1	84003-1	Washer-#10	4
88509	Bearing-thrust	2	88641	Pin-trigger (atch)	1	84103	7/16 x 3/16 x 1/16	2
A-88511	Bearing-needle	1	A-88642	Piston & Pin	1	86081	Rivet-tubular	2
88512	Bearing-needle	1	A-88643-C	Cylinder & Crankcase	1	88021	8-32 x 1	4
			A-88644-1	Engine Cover	1			

\* Denotes new parts

823711EY

# HOMELITE TEXTRON

Homelite Division of Textron Inc.